



TEMPERATURE ELEMENTS AND TRANSMITTER

TEMPERATURE ELEMENTS AND TRANSMITTER

MODEL CAT. NO

.....

Metallic Protection Tube Thermocouples.....	R111, R112	RD01-01
Sheathed Thermocouples.....	R121, R122	RD01-02
Metallic Protection Tube Resistance Temperature Detector	R211, R212	RD02-01
Sheathed Resistance Temperature Detector	R221, R222	RD02-01
Extension Lead Wire Thermocouples & Resistance Temperature Detector	R311, 312, 321, 322, 331, 332...	RD03-01
Multi Thermocouple & Resistance Temperature Detector	R511, R512, R521, R522	RD05-01
Skin Thermocouple	R601, R602, R611, R612	RD06-01
Non-Metallic Protection Tube Thermocouples	R701, R702	RD07-01
Temperature Transmitter (Sensor Parts)	R911, R912	RD09-01
Temperature Transmitter (Electronic Parts).....	MTM	RD09-02
Temperature Element Reference DWG		RD09-03

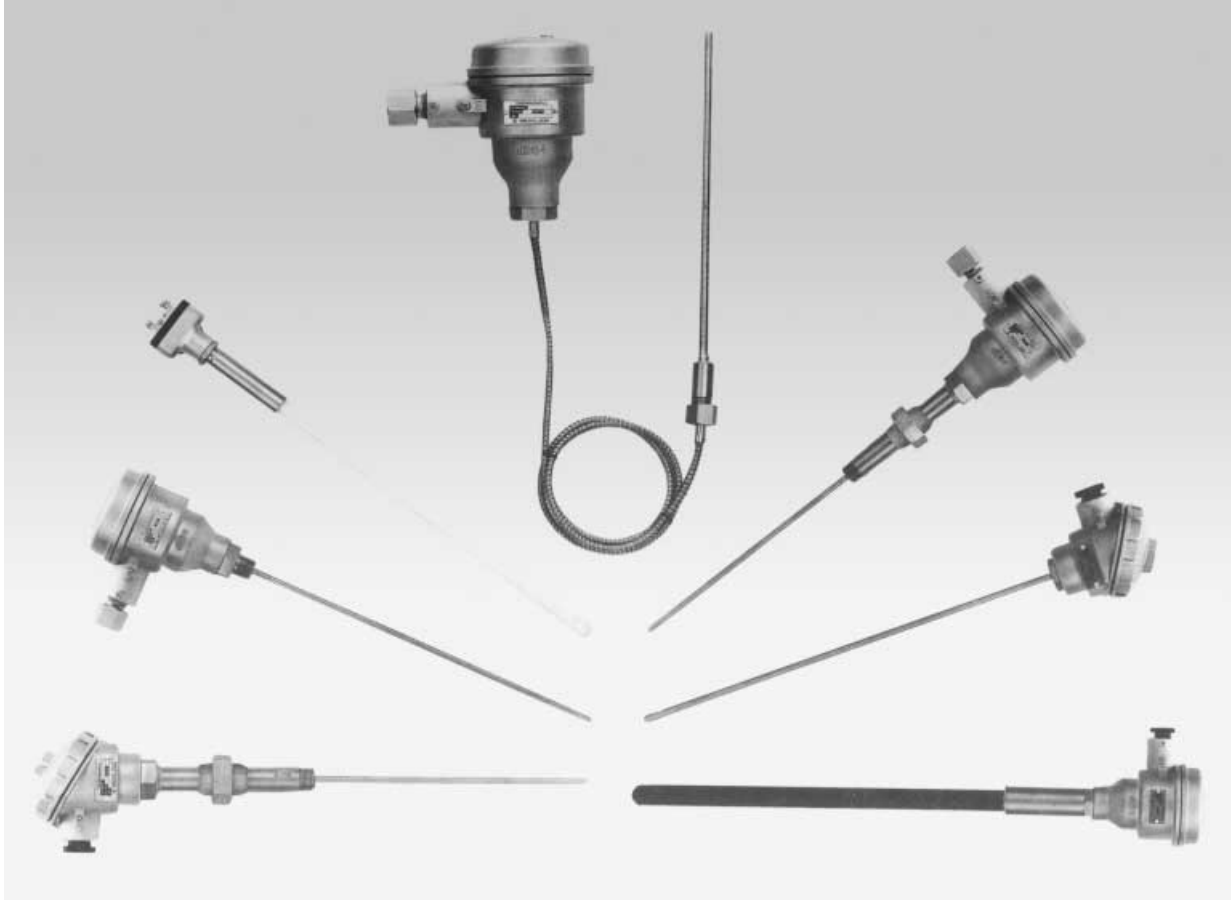

THERMOCOUPLES

INTRODUCTION

When two dissimilar conductors are connected together to form a closed circuit and the two junctions are kept in different temperatures, thermal electromotive force (EMF) is generated in the circuit (Seebeck's Effect). Thus, when one end (Cold Junction) is kept constant at a certain temperature, normally at 0°C, and the other end (Measuring Junction) is exposed to unknown temperature, the temperature at latter end can be determined by measurement of EMF so generated. This combination of two dissimilar conductors are called "Thermocouple"

1. CHARACTERISTICS

-Type T (Copper vs Constantan)
Is used for service in oxidizing, inert or reducing atmospheres or in vacuum. It is highly resistant to corrosion from atmospheric moisture and condensation and exhibits high stability at low temperatures; it is the only type with limits of error guaranteed for cryogenic temperatures.

-Type J (Iron vs Constantan)
Is used protected or unprotected in vacuum, oxidizing, inert or reducing atmospheres. Iron element oxidizes rapidly at temperatures exceeding 1000°C, and therefore heavier gauge wire is recommended for longer life at these temperatures.

-Type E (Chromel vs Constantan)
May be used protected or unprotected in oxidizing, inert or dry reducing atmospheres, or for short periods of time under vacuum. Must be protected from sulfurous and degree of any standardized thermocouple.

-Type K (Chromel vs Alumel)
Is used protected or exposed in oxidizing, inert or dry reducing atmospheres. Exposure to vacuum limited to short time periods. Must be protected from sulfurous and marginally oxidizing atmospheres. Reliable and accurate at high temperatures.

-Type S (Platinum 10 %, Rhodium vs Platinum)
-Type R (Platinum 13 %, Rhodium vs Platinum)
-Type B (Platinum 30 %, Rhodium vs Platinum 6% Rhodium)
are all recommended for use in inert or oxidizing atmosphere, or for short periods of time in a vacuum. Easily contaminated, these elements must be protected from the effects of reducing atmospheres and contaminating vapors. Alumina protecting tubes are recommended for directly containing platinum elements.

2. STRUCTURE

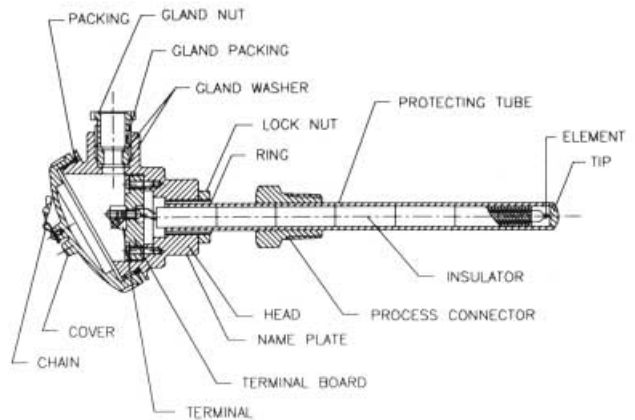

3. EMF CHART TYPICAL THERMOCOUPLE

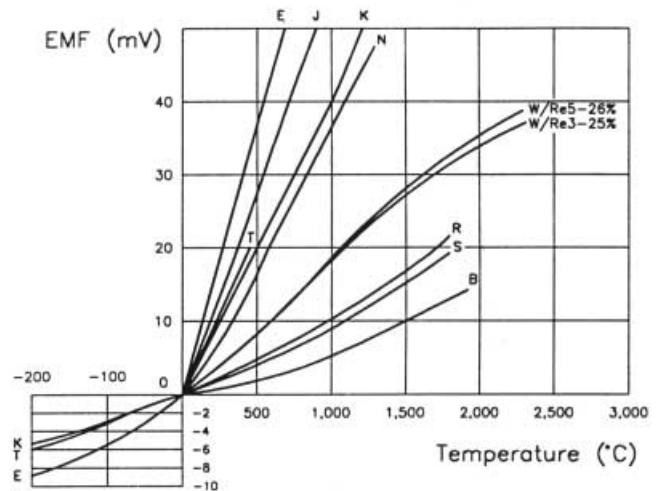

4. TOLERANCE FOR TEMPERATURE READING

Ref: JIS C 1602-1981

Type	Old JIS Type	Combination of Element Wires	
		Positive (+) Leg	Negative (-) Leg
B		70% Platinum/30% Rhodium	94% Platinum/6% Rhodium
R	PR*	87% Platinum/13% Rhodium	100% Platinum
S	...	90% Platinum/10% Rhodium	100% Platinum
K	CA	Chromel**(90% Ni/10% Cr)	Alumel**(95% Ni/2% Mn/2% Al)
E	CRC	Chromel**(90% Ni/10% Cr)	Constantan(55% Cu/45%Ni)
J	IC	99.5% Iron	Constantan(55% Cu/45%Ni)
T	CC	100% Copper	Constantan(55% Cu/45%Ni)
N	...	Nicrosil (84% Ni/14.2% Cr/1.45% Si)	Nisil (95% Ni/4.4% Si/0.15% Mg)

NOTE * Old type PR does not correspond to the present type R because of different content of Rhodium in positive (+) leg.

** Chromel and Alumel are the registered trade marks by Hoskins Mfg. Co., U.S.A.

Type	Old JIS Type	Temperature Range	Class	Tolerance Ref: JIS C 1602-1981
B		600°C ~ 1,700°C	0.5	±4°C or ±0.5% of Reading
R	PR13	0°C ~ 1,600°C	0.25	±1.5°C or ±0.25% of Reading
K	CA	0°C ~ 1,000°C	0.4	±1.5°C or ±0.4% of Reading
		0°C ~ 1,200°C	0.75	±2.5°C or ±0.75% of Reading
E	CRC	0°C ~ 800°C	0.4	±1.5°C or ±0.4% of Reading
		0°C ~ 800°C	0.75	±2.5°C or ±0.75% of Reading
J	IC	0°C ~ 750°C	0.4	±1.5°C or ±0.4% of Reading
		0°C ~ 750°C	0.75	±2.5°C or ±0.75% of Reading
T	CC	0°C ~ 350°C	0.4	±0.5°C or ±0.4% of Reading
		0°C ~ 350°C	0.75	±1°C or ±0.75% of Reading
		-200°C ~ 0°C	1.5	±1°C or ±1.5% of Reading
N	---	0°C ~ 1250°C	0.75	±2.5°C or ±0.75% of Reading

NOTE *Tolerance means means maximum allowable limit calculated by deducting the temperature at hot junction from the temperature value converted from EMF Table.
The tolerance shall be expressed in either °C or % whichever larger.

5. TYPICAL RESISTANCE OF STANDARD THERMOCOUPLE

Ref: JIS C 1602-1981 *Hoskins Unit: Ω/m

Type Old JIS Type	B	R	S	K	E	J	T	N*	
									PR
28	0.32	•	•	•	•	•	6.17	16.43	
24	0.50	1.75	1.47	1.43	•	•	•	6.50	
22	0.65	•	•	•	2.95	3.56	1.70	1.50	4.08
18	1.00	•	•	•	1.25	1.50	0.72	0.63	1.62
14	1.60	•	•	•	0.49	0.59	0.28	0.25	0.64
11	2.30	•	•	•	0.24	0.28	0.14	•	0.32
8	3.20	•	•	•	0.12	0.15	0.07	•	0.13

Note: Resistance at 0°C (R₀) measured between (+) and (-) legs.

6. OPERATING AND MAXIMUM TEMPERATURE LIMITS

Type	Old JIS	Wire Dia.	Operating Temp.	Maximum Limit
		(mm)	Limit(°C)(1)	(°C)(2)
B	•	0.50	1,500	1,700
R	PR	0.50	1,400	1,600
S	•	0.65	650	850
K	CA	1.00	750	950
		1.60	850	1,050
		2.30	900	1,100
		3.20	1,000	1,200
		0.65	450	500
E	CRC	1.00	500	550
		1.60	550	650
		2.30	600	750
		3.20	700	800
		0.65	400	500
J	IC	1.00	450	550
		1.60	500	650
		2.30	550	750
		3.20	600	750
		0.32	200	250
T	CC	0.65	200	250
		1.00	250	300
		1.60	300	350
N	•	1.60	900	1,100
		2.30	1,100	1,200
		3.20	1,200	1,300

Note (1) Operating temperature limit means the upper temp, where thermocouple can be used continuously in air.

(2) Maximum limit means the upper temp, where thermocouple can be used temporarily owing to inevitable circumstances.

7. INSULATING TUBES AND PROTECTION TUBES

METALLIC TUBES

Material	Operating Temp.(°C)	Maximum Temp.(°C)
304SS	900	1,000
316SS	900	1,000
304SS	900	1,000
316SS	900	1,000
321SS	900	1,000
310SS	950	1,050
347SS	900	1,000
446SS	1,050	1,125
Inconel600	1,180	1,250
Inconel800	870	1,000
Hastelloy-C	1,000	1,100
Hastelloy-B	800	1,100
Titanium	Oxi.250 red.1,000	
Monel	500	600
Tantalum	Oxi.300 red.2,200	

NON-METALLIC TUBES

Material	Operating Temp.(°C)	Maximum Temp.(°C)
Ceramic Grade 2 (NC)	1400	1450
Ceramic Grade 1 (HB)	1500	1550
Alumina (SSA-H)	1600	1700
Pure Alumina (SSA-S)	1800	1900
Silicon Carbide (SiC)	2300	2400

8. SHEATHED THERMOCOUPLE



Sheathed Thermocouple is one sheathed thermocouple that is composed of a fine gauged metal sheath in which high purity MgO powder is tightly compacted around thermoelement wires.

Sheathed Thermocouple has high insulation and pressure resistance. It has also high reliability because of its EMF tolerance falling within the limits stipulated by JIS, ANSI, BS, DIN, etc.

-Features

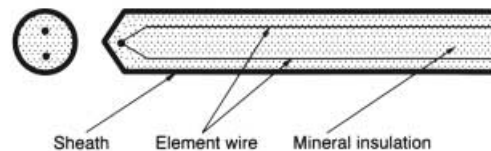
- Quick response:
By virtue of its integrated structure composed of thermoelement wires insulating material and a protection tube, one has very quick response to temperature change.
- High flexibility and mechanical strength:
With its tightly compacted form, sheathed thermocouple has mechanical strength and pliability up to bending radius equal to 2 time of the sheath O.D
- Excellent resistance to heat Corrosion and Pressure
As high purity MgO powder is tightly compacted in a heat resistant metal tube, Sheath thermocouple is highly gas-tight, no corrosion from surrounding atmospheres and withstand high pressures up to 500kg/cm².
- Wide selection of cable specifications :
From very fine gauge of 0.25mm to 12.7mm in O.D. and up to 300meters in length are available. Thermoelement wires of 2-pair and 3-pair are also available.

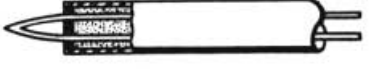

<p>Grounded</p> 	<p>Thermoelement wires are welded together directly at hot end of the sheath to form a hot junction</p>
	<p>Quick response and suitable at high temperature and pressure but not recommendable for use in critical and noise generating field.</p>
<p>Ungrounded</p> 	<p>Thermoelement wires are welded together to form a hot junction which is completely insulated from the sheath.</p>
	<p>Slower response than grounded but less aging deterioration of EMF and good for long service in critical and noise generating field.</p>
<p>Exposed</p> 	<p>Both ends of thermoelement wires are welded together to form a hot junction protruding from sheath.</p>
	<p>Quickest response and can detect even slight temperature change but not usable for long time in corrosive, high temperature and high pressure atmospheres.</p>

-Operating temperature and typical resistance of sheathed thermocouple

Sheath Outdia.	Sheath Thickness (mm)	Wire Dia.(mm)	K			T		J		E		
			Operating Temp.		Resistance	Operating Temp.	Resistance	Operating Temp.	Resistance	Operating Temp.		Resistance
			316SS 347SS	310SS Inconel	Ω/m	316SS	Ω/m	316SS 347SS	Ω/m	316SS 347SS	Inconel	Ω/m
1.0mm	0.15	0.2	450°C	•	31.8	200°C	16.2	250°C	19.4	450°C	•	38.0
1.6mm	0.2	0.32	600°C	700°C	12.4	250°C	6.3	350°C	7.6	600°C	700°C	14.9
3.2mm	0.4	0.53	700°C	900°C	4.5	250°C	2.3	450°C	2.8	700°C	900°C	5.4
4.8mm	0.5	0.77	800°C	1,000°C	2.2	300°C	1.1	500°C	1.3	800°C	1,000°C	2.6
6.4mm	0.6	1.14	850°C	1,050°C	1.0	300°C	0.5	550°C	0.6	850°C	1,050°C	1.2
8.0mm	0.7	1.3	900°C	1,050°C	0.8	300°C	0.4	600°C	0.5	900°C	1,050°C	0.9

THERMOCOUPLE EMF TABLE

Type B Thermocouple

ANSI MC96.1 1982
JIS C 1602 1981 Unit: mV

°C	0	100	200	300	400	500	600	700	800	900	1,000	1,100	1,200	1,300	1,400	1,500	1,600	1,700	1,800	°C
0	0.000	0.033	0.178	0.431	0.786	1.241	1.791	2.430	3.154	3.957	4.833	5.777	6.783	7.845	8.952	10.094	11.257	12.426	13.585	0
10	-0.002	0.043	0.199	0.462	0.827	1.292	1.851	2.499	3.231	4.041	4.924	5.875	6.887	7.953	9.065	10.210	11.374	12.543	13.699	10
20	-0.003	0.053	0.220	0.494	0.870	1.344	1.912	2.569	3.308	4.126	5.016	5.973	6.991	8.063	9.178	10.325	11.491	12.659	13.814	20
30	-0.002	0.065	0.243	0.527	0.913	1.397	1.974	2.639	3.387	4.212	5.109	6.073	7.096	8.172	9.291	10.441	11.608	12.776		30
40	0.000	0.078	0.266	0.561	0.957	1.450	2.036	2.710	3.466	4.298	5.202	6.172	7.202	8.283	9.405	10.558	11.725	12.892		40
50	0.002	0.092	0.291	0.598	1.002	1.505	2.100	2.782	3.546	4.386	5.297	6.273	7.308	8.393	9.519	10.674	11.842	13.008		50
60	0.006	0.107	0.317	0.632	1.048	1.560	2.164	2.855	3.626	4.474	5.391	6.374	7.414	8.504	9.634	10.790	11.959	13.124		60
70	0.011	0.123	0.344	0.669	1.095	1.617	2.230	2.928	3.708	4.562	5.487	6.475	7.521	8.616	9.748	10.907	12.076	13.239		70
80	0.017	0.140	0.372	0.707	1.143	1.674	2.296	3.003	3.790	4.652	5.583	6.577	7.628	8.727	9.863	11.024	12.193	13.354		80
90	0.025	0.159	0.401	0.746	1.192	1.732	2.363	3.078	3.873	4.742	5.680	6.680	7.736	8.839	9.974	11.141	12.310	13.470		90
100	0.033	0.178	0.431	0.786	1.241	1.791	2.430	3.154	3.957	4.833	5.777	6.783	7.845	8.952	10.094	11.257	12.426	13.585		100

Type S Thermocouple

ANSI MC96.1 1982
JIS C 1602 1981 Unit: mV

0	100	200	300	400	500	600	700	800	900	1,000	1,100	1,200	1,300	°C	1,400	1,500	1,600	1,700	°C
0.000	0.645	1.440	2.323	3.260	4.234	5.237	6.274	7.345	8.448	9.585	10.754	11.947	13.155	0	14.368	15.576	16.771	17.942	0
0.055	0.719	1.525	2.414	3.356	4.333	5.339	6.380	7.454	8.560	9.700	10.872	12.067	13.276	10	14.489	15.697	16.890	18.056	10
0.113	0.795	1.611	2.506	3.452	4.432	5.442	6.486	7.563	8.673	9.816	10.991	12.188	13.397	20	14.610	15.817	17.008	18.170	20
0.173	0.872	1.698	2.599	3.549	4.532	5.544	6.592	7.672	8.786	9.932	11.110	12.308	13.519	30	14.731	15.937	17.125	18.282	30
0.235	0.950	1.785	2.692	3.645	4.632	5.648	6.699	7.782	8.899	10.048	11.229	12.429	13.640	40	14.852	16.057	17.243	18.394	40
0.299	1.029	1.873	2.786	3.743	4.732	5.751	6.805	7.892	9.012	10.165	11.348	12.550	13.761	50	14.973	16.176	17.360	18.504	50
0.365	1.109	1.962	2.880	3.840	4.832	5.855	6.913	8.003	9.126	10.282	11.467	12.671	13.883	60	15.094	16.296	17.477	18.612	60
0.432	1.190	2.051	2.974	3.938	4.933	5.960	7.020	8.114	9.240	10.400	11.587	12.792	14.004	70	15.215	16.415	17.594		70
0.502	1.273	2.141	3.069	4.036	5.034	6.064	7.128	8.225	9.355	10.517	11.707	12.913	14.125	80	15.336	16.534	17.711		80
0.573	1.356	2.232	3.164	4.135	5.136	6.169	7.236	8.336	9.470	10.635	11.827	13.034	14.247	90	15.456	16.653	17.826		90
0.645	1.440	2.323	3.260	4.234	5.237	6.274	7.345	8.448	9.585	10.754	11.947	13.155	14.368	100	15.576	16.771	17.942		100

Type R Thermocouple

ANSI MC96.1 1982
JIS C 1602 1981 Unit: mV

°C	0	100	200	300	400	500	600	700	800	900	1,000	1,100	1,200	1,300	1,400	1,500	1,600	1,700	°C
0	0.000	0.647	1.468	2.400	3.407	4.471	5.582	6.741	7.949	9.203	10.503	11.846	13.224	14.624	16.035	17.445	18.842	20.215	0
10	0.054	0.723	1.557	2.498	3.511	4.580	5.696	6.860	8.072	9.331	10.636	11.983	13.363	14.765	16.176	17.585	18.981	20.350	10
20	0.111	0.800	1.647	2.596	3.616	4.689	5.810	6.979	8.196	9.460	10.768	12.119	13.502	14.906	16.317	17.726	19.119	20.483	20
30	0.171	0.879	1.738	2.695	3.721	4.799	5.925	7.098	8.320	9.589	10.902	12.257	13.642	15.047	16.458	17.866	19.257	20.616	30
40	0.232	0.959	1.830	2.795	3.826	4.910	6.040	7.218	8.445	9.718	11.035	12.394	13.782	15.188	16.599	18.006	19.395	20.748	40
50	0.296	1.041	1.923	2.896	3.933	5.021	6.155	7.339	8.570	9.848	11.170	12.532	13.922	15.329	16.741	18.146	19.533	20.878	50
60	0.363	1.124	2.111	2.997	4.039	5.132	6.272	7.460	8.696	9.978	11.304	12.669	14.062	15.470	16.882	18.286	19.670	21.006	60
70	0.431	1.208	2.207	3.099	4.146	5.244	6.388	7.582	8.822	10.109	11.439	12.808	14.202	15.611	17.022	18.425	19.807		70
80	0.501	1.294	2.141	3.201	4.254	5.356	6.505	7.703	8.949	10.240	11.574	12.946	14.343	15.752	17.163	18.564	19.944		80
90	0.573	1.380	2.303	3.304	4.362	5.469	6.623	7.826	9.076	10.371	11.710	13.085	14.483	15.893	17.304	18.703	20.080		90
100	0.647	1.468	2.400	3.407	4.471	5.582	6.741	7.949	9.203	10.503	11.846	13.224	14.624	16.035	17.445	18.842	20.215		100

Type K Thermocouple

ANSI MC96.1 1982
JIS C 1602 1981 Unit: mV

°C	-100	-0	°C	0	100	200	300	400	500	600	700	800	900	1,000	1,100	1,200	1,300	°C
-0	-3.553	0.000	0	0.000	4.095	8.137	12.207	16.395	20.640	24.902	29.128	33.27	37.325	41.269	45.108	48.828	52.398	0
-10	-3.852	-0.392	10	0.397	4.508	8.537	12.623	16.818	21.066	25.327	29.547	33.686	37.724	41.657	45.486	49.192	52.747	10
-20	-4.138	-0.777	20	0.798	4.919	8.938	13.039	17.241	21.493	25.751	29.965	34.095	38.122	42.045	45.863	49.555	53.093	20
-30	-4.410	-1.156	30	1.203	5.327	9.341	13.456	17.664	21.919	26.176	30.383	34.502	38.519	42.432	46.238	49.916	53.439	30
-40	-4.699	-1.527	40	1.611	5.733	9.745	13.874	18.088	22.346	26.599	30.799	34.909	38.915	42.817	46.612	50.276	53.782	40
-50	-4.912	-1.898	50	2.022	6.137	10.151	14.292	18.513	22.772	27.022	31.214	35.314	39.310	43.202	46.985	50.633	54.125	50
-60	-5.141	-2.243	60	2.436	6.539	10.560	14.712	18.938	23.198	27.445	31.629	35.718	39.703	43.585	47.356	50.990	54.466	60
-70	-5.354	-2.586	70	2.850	6.939	10.969	15.132	19.363	23.624	27.867	32.042	36.121	40.096	43.968	47.726	51.344	54.807	70
-80	-5.550	-2.920	80	3.266	7.338	11.381	15.552	19.788	24.050	28.288	32.455	36.524	40.488	44.349	48.095	51.697		80
-90	-5.730	-3.242	90	3.681	7.737	11.793	15.974	20.214	24.476	28.709	32.866	36.925	40.879	44.729	48.462	52.049		90
-100	-5.891	-3.553	100	4.095	8.137	12.207	16.395	20.640	24.902	29.128	33.277	37.325	41.269	45.108	48.828	52.398		100

Type J Thermocouple

ANSI MC96.1 1982
JIS C 1602 1981 Unit: mV

°C	-100	-0	°C	0	100	200	300	400	500	600	700	800	900	1,000	1,100	°C
-0	-4.632	0.000	0	0.000	5.268	10.777	16.325	21.846	27.388	33.096	39.130	45.498	51.875	57.942	63.777	0
-10	-5.036	-0.501	10	0.507	5.812	11.332	13.879	22.397	27.949	33.683	39.754	46.144	52.496	58.533	64.355	10
-20	-5.426	-0.995	20	1.019	6.359	11.887	17.432	22.949	28.511	34.273	40.382	46.790	53.115	59.121	64.933	20
-30	-5.801	-1.481	30	1.536	6.907	12.442	17.984	23.501	29.075	34.867	41.013	47.434	53.729	59.708	65.510	30
-40	-6.159	-1.960	40	2.058	7.457	12.996	18.537	24.054	29.642	35.464	41.647	48.076	54.341	60.293	66.067	40
-50	-6.499	-2.431	50	2.585	8.008	13.553	19.089	24.607	30.210	36.066	42.283	48.716	54.948	60.876	66.664	50
-60	-6.821	-2.892	60	3.115	8.560	14.108	19.640	25.161	30.782	36.671	42.922	49.354	55.553	61.459	67.240	60
-70	-7.122	-3.344	70	3.649	9.113	14.663	20.192	25.716	31.356	37.280	43.563	49.989	56.155	62.03962	67.815	70
-80	-7.402	-3.785	80	4.186	9.667	15.217	20.743	26.272	31.933	37.893	44.207	50.621	56.753	619	68.390	80
-90	-7.659	-4.215	90	4.725	10.222	15.771	21.295	26.829	32.513	38.510	44.852	51.249	57.349	63.199	68.964	90
-100	-7.890	-4.632	100	5.268	10.777	16.325	21.846	27.388	33.096	39.130	45.498	51.875	57.942	63.777	69.536	100

Type E Thermocouple

ANSI MC96.1 1982
JIS C 1602 1981 Unit: mV

°C	-100	-0	°C	0	100	200	300	400	500	600	700	800	900	°C
-0	-5.237	0.000	0	0.000	6.317	13.419	21.033	28.943	36.999	45.085	53.110	61.022	68.783	0
-10	-5.680	-0.581	10	0.591	6.996	14.161	21.814	29.744	37.808	45.891	53.907	61.806	69.549	10
-20	-6.107	-1.151	20	1.192	7.983	14.909	22.597	30.546	38.617	46.697	54.703	62.588	70.313	20
-30	-6.516	-1.709	30	1.801	8.377	15.661	23.383	31.350	39.426	47.502	55.498	63.368	71.075	30
-40	-6.907	-2.254	40	2.419	9.078	16.417	24.171	32.155	40.236	48.306	56.291	64.147	71.835	40
-50	-7.279	-2.787	50	3.047	9.787	17.178	24.961	32.960	41.045	49.109	57.083	64.924	72.593	50
-60	-7.631	-3.306	60	3.683	10.501	17.942	25.754	33.767	41.853	49.911	57.873	65.700	73.350	60
-70	-7.963	-3.811	70	4.329	11.222	18.710	26.549	34.574	42.662	50.713	58.663	66.473	74.104	70
-80	-8.273	-4.301	80	4.983	11.949	19.481	27.354	35.382	43.470	51.513	59.451	67.245	74.857	80
-90	-8.561	-4.777	90	5.646	12.681	20.256	28.143	36.190	44.278	52.312	60.237	68.015	75.608	90
-100	-8.824	-5.237	100	6.317	13.419	21.033	28.943	36.999	45.085	53.110	61.022	68.783	76.358	100

Type T Thermocouple

ANSI MC96.1 1982
JIS C 1602 1981 Unit: mV

°C	-200	-100	-0	°C	0	100	200	300	°C
-0	-5.603	-3.378	0.000	0	0.000	4.277	9.286	14.860	0
-10	-5.753	-3.656	-0.383	10	0.391	4.749	9.820	15.443	10
-20	-5.889	-3.923	-0.757	20	0.789	5.227	10.360	16.030	20
-30	-6.007	-4.177	-1.121	30	1.196	5.712	10.905	16.621	30
-40	-6.105	-4.419	-1.475	40	1.611	6.204	11.456	17.217	40
-50	-6.181	-4.648	-1.819	50	2.035	6.702	12.011	17.816	50
-60	-6.232	-4.865	-2.152	60	2.467	7.207	12.572	18.420	60
-70	-6.258	-5.069	-2.475	70	2.908	7.718	13.137	19.027	70
-80		-5.261	-2.788	80	3.357	8.235	13.707	20.252	80
-90		-5.439	-3.089	90	3.813	8.757	14.281	20.869	90
-100		-5.603	-3.378	100	4.277	9.286	14.860		100

Type N Thermocouple

ANSI MC96.1 1982
JIS C 1602 1981 Unit: mV

°C	0	100	200	300	400	500	600	700	800	900	1,000	1,100	1,200	1,300	°C
0	0.000	2.744	5.912	8.340	12.927	16.744	20.609	24.526	28.456	32.370	36.248	40.076	43.836	47.502	0
10	0.261	3.072	6.243	9.695	13.344	17.127	20.999	24.919	28.849	32.760	36.633	40.456	44.207		10
20	0.525	3.374	6.577	10.053	13.717	17.511	21.390	25.312	29.241	3.149	37.018	40.835	44.578		20
30	0.793	3.679	6.914	10.412	14.092	17.896	21.781	25.705	29.633	3.538	37.403	41.213	44.947		30
40	1.064	3.988	7.254	10.773	14.467	18.282	22.172	26.098	30.025	33.927	37.786	41.590	45.315		40
50	1.340	4.301	7.596	11.135	14.844	18.668	22.564	26.491	30.417	34.315	38.169	41.966	45.682		50
60	1.619	4.617	7.940	11.499	15.222	19.055	22.956	26.885	30.808	34.702	38.552	42.342	46.048		60
70	1.902	4.936	8.287	11.865	15.601	19.443	23.348	27.278	31.199	35.089	38.934	42.717	46.413		70
80	2.188	5.258	8.636	12.233	15.981	19.831	23.747	27.671	31.590	35.476	39.316	43.091	46.777		80
90	2.479	5.584	8.987	12.602	16.362	20.220	24.133	28.063	31.980	35.862	39.696	43.464	47.140		90
100	2.774	5.912	8.340	12.927	16.744	20.609	24.526	28.456	32.370	36.248	40.076	43.836	47.502		100

TEMP ELEMENT

RESISTANCE TEMPERATURE DETECTOR

INTRODUCTION

Resistance temperature detectors (RTD's) operate under the principle the electrical resistance of certain metals increases or decreases in a repeatable and predictable manner with a temperature change. RTD's may have a lower temperature range than some thermocouples and a slower response time however they are more stable and repeatable over long periods of time. RTD's are used in chemical and petrochemical industry, pulp and paper industry. RTD's are available in the same configurations as thermocouples to suit applications.

1. STRUCTURE

Metal wire that changes of its electric resistance to changes in temperature are utilized is called "Resistance wires"

This resistance wire, normally of platinum, is used for manufacturing a temperature sensor called "Resistance temperature detector (RTD) element". Generally speaking RTD is composed of RTD element, lead wire, protection tube and terminals.

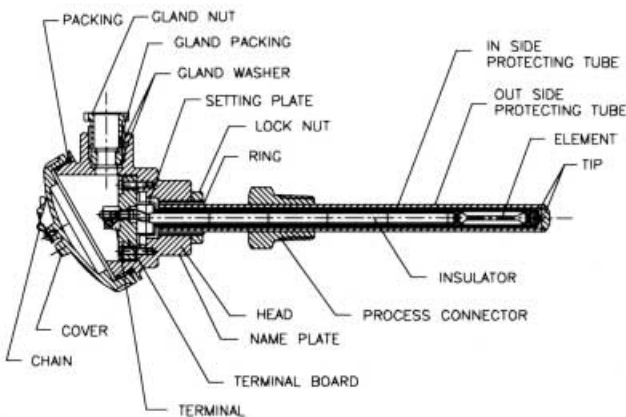

2. LEAD WIRES CONNECTION METHOD

-2 wires connection :

One wire is connected to one end of the RTD. Generally used when the changes in lead wires resistance due to ambient temperature changes can be ignored.

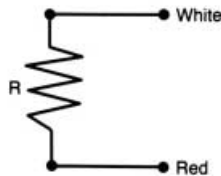

-3 wires connection :

Two wires are connected to one end of the RTD and one wires to the other. This is the most commonly used. The third wire compensates for changes in lead wire resistance.

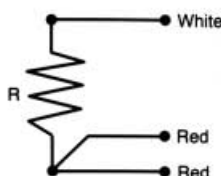

-4 wire connection

Two wires are connected to each end of the RTD

This type of connection is used for high precision measurements.

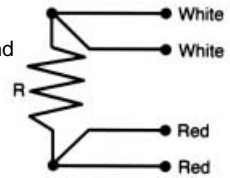

3. TEMPERATURE TOLERANCE

TYPE	Nominal resistance (Ω at 0 °C)	Resistance ratio R100/R0	Class	Tolerance (°C)	Rated current (mA)
Pt100	100	1,3850	A	±(0.15+0.002 t)	1,2
			B	±(0.3+0.005 t)	1,2,5

*R100 is resistance value at 100°C
R0 is resistance value at 0°C

Measuring temp(°C)	-200	-100	0	100	200	300	400	500	600	650
	Tolerance	Class A ±0.55	±0.35	±0.15	±0.35	±0.55	±0.75	±0.95	±1.15	±1.35
	Class B ±1.3	±0.8	±0.3	±0.8	±1.3	±1.8	±2.3	±2.3	±3.3	±3.6

4. TYPE OF PLATINUM RTD ELEMENT

-Glass sealed platinum RTD element :

It is composed of a high purity platinum wire wound noninductively around a special glass body, of which resistivity at 0 °C is adjusted to fall within the respective standard ranges, instead of another special glass tube and heat sealed overall. Quick response and excellent in insulation, withstand voltage, vibration and high resistance to liquid, chemicals and gases.

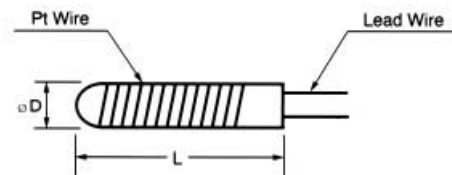

Type	Nom. resistance (°C)	Resistance ratio R100/R0	Dimension(mm)		Operating temp. (0°C)	Rated current (mA)	Class
			L(mm)	W(mm)			
RG20S	100	1.3850	25	2.0	-200~400	5Max.	A B
RG30S	100		25	3.0			
RG40S	100		25	4.0			

-MICA type platinum RTD element :

It is composed of a mica plate wound with a high purity platinum wire and sandwiched between two mica plates for insulation and between two stainless steel plate springs, and fixed tightly by stainless steel wires. Because of ease in handling and rigid structure, it is being used widely in industrial applications.

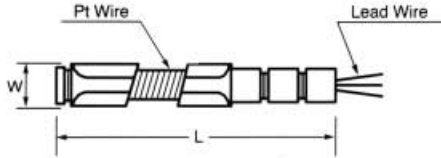

Type	Nom. resistance (Ω)	Resistance R100/R0	L(mm)	W(mm)	I.D. of protection tube(mm)	Operating temp. (0° C)	Rated current (mA)	Class
RM30S	100	1,3850	50	3.0	4.5			
RM35D	100		50	3.5	4.5			
RM35S	100×2		50	4.0	5.0			
RM40S	100							
RM40D	100×2		50	5.0	6.0			
RM50S	100							
RM50D	100×2		50	7.0	8.0			
RM70S	100							
RM70D	100×2		50	8.0	9.0			
RM80S	100							
RM80D	100×2		50	9.0	10.0			
RM90S	100							
RM90D	100×2		50	10.0	11.0~16.0			
RM100S	100							
RM100D	100×2							

-Ceramic type platinum RTD element

It is composed of a coil-formed high purity platinum wire instead of bored of a fine polished recrystallized alumina ceramic body and fixed on its bottom by special heat resistant frit. As approximately 80% of the resistance wire is free of heat strain from temperature change, drift in resistivity is minimized and its reproducibility and long term stability are superior to any of conventional core-wound element.

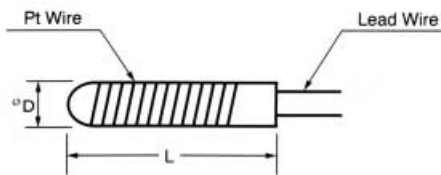

Type	Nom. resistance (Ω)	Resistance R100/R0	Dimension		Operating temp. (0° C)	Rated current (mA)	Class
			L(mm)	W(mm)			
RC09S	100	1.3850	15	0.9	-200~600	2Max	A
RC12S	100		15	1.2			
RC30S	100		25	1.6			
RC30D	100		25	3.0			
RC45S	100×2		25	3.0		5Max	B
RC45D	100		30	4.5			
	100×2		30	45			

5.SHEATHED RTD

-Sheathed RTD is a registered trade name of one metal sheathed RTD that has a monolithic structure comprising of sheathed element and MI Cable (MgO compacted, metal sheathed lead wires). This is newly developed RTD with quick response, longer service and life and high accuracy under critical conditions.

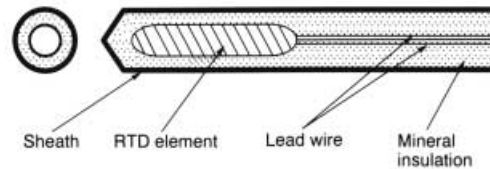

-Features

- Quick response
- High flexibility
- High accuracy
- Wide selection of specification : Available for outer diameters from 3.2mm to 8.0mm and total length up to 150mm

-Sheathed RTD response time

The Time Constants (63.2%) when sheathed RTD is immersed into 100℃ (boiling water) from 0℃ (ice bath.)

- 3.2 less than 2sec
- 4.8 less than 4sec
- 6.4 less than 6sec
- 8.0 less than 11sec

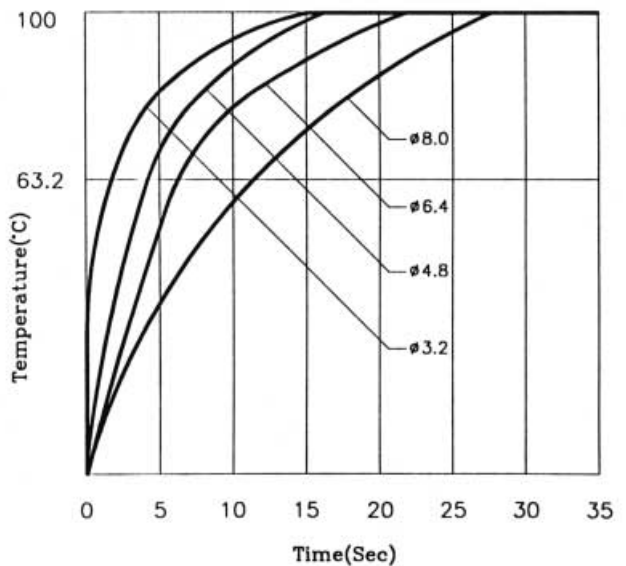

-Temperature resistance table
 Nominal Resistance for Pt 100Ω Element
 JIS C 1604, C 1606, DIN 43760, BS 1904, IEC 751

Std °C	JIS	DIN BS IEC	Std °C	JIS	DIN BS IEC	Std °C	JIS	DIN BS IEC
-200	17.14	18.49	0	100.00	100.00	200	177.13	175.84
-190	21.46	22.80	10	103.97	103.90	210	180.86	179.51
-180	25.80	27.08	20	107.93	107.79	220	184.58	183.17
-170	30.12	31.32	30	111.88	111.67	230	188.29	186.82
-160	34.42	35.53	40	115.81	115.54	240	191.99	190.45
-150	38.68	39.71	50	119.73	119.40	250	195.67	194.07
-140	42.91	43.87	60	123.64	123.24	260	199.35	197.69
-130	47.11	48.00	70	127.54	127.07	270	203.01	201.29
-120	51.29	52.11	80	131.42	130.89	280	206.66	204.88
-110	55.44	56.19	90	135.30	134.70	290	210.30	208.45
-100	59.57	60.25	100	139.16	138.50	300	213.93	212.02
-90	63.68	64.30	110	143.01	142.29	310	217.54	215.57
-80	67.77	68.33	120	146.85	146.06	320	221.15	219.12
-70	71.85	72.33	130	150.67	149.82	330	224.74	222.65
-60	75.91	76.33	140	154.49	153.58	340	228.32	226.17
-50	79.96	80.31	150	158.29	157.31	350	231.89	229.67
-40	83.99	84.27	160	162.08	161.04	360	235.45	233.17
-30	88.01	88.22	170	165.86	164.76	370	238.99	236.65
-20	92.02	92.16	180	169.63	168.46	380	242.53	240.132
-10	96.02	96.09	190	173.38	172.16	390	246.05	43.59

Tolerances as a Function of Temperature/
 Resistance for Pt 100Ω Element

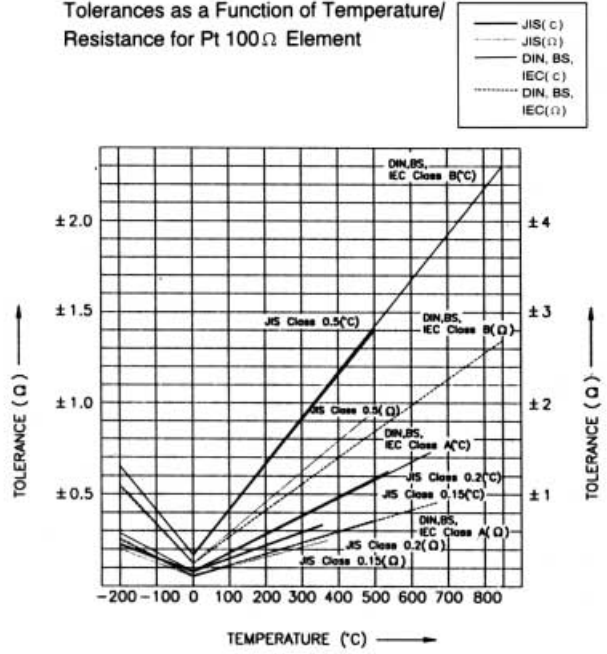

Std °C	JIS	DIN BS IEC	Std °C	JIS	DIN BS IEC	Std °C	JIS	DIN BS IEC
400	249.56	247.04	600	317.28	313.59	800		375.51
410	253.06	250.48	610	320.54	316.80	810		378.48
420	256.55	253.90	620	323.78	319.99	820		381.45
430	260.02	257.32	630	327.02	323.18	830		384.40
440	263.49	260.72	640	330.24	326.35	840		387.34
450	266.94	264.11	650		329.51	850		390.26
460	270.38	267.49	660		332.66			
470	273.80	270.86	670		335.79			
480	277.22	274.22	680		338.92			
490	280.63	277.56	690		345.13			
500	284.02	280.90	700		348.22			
510	287.40	284.22	710		351.30			
520	290.77	287.53	720		354.37			
530	294.12	290.83	730		357.42			
540	297.47	294.11	740		360.47			
550	300.80	297.39	750		363.50			
560	304.12	300.65	760		366.52			
570	307.43	303.91	770		369.53			
580	310.72	307.15	780		372.52			
590	314.01	310.38	790					

● Head type(WISE standard)

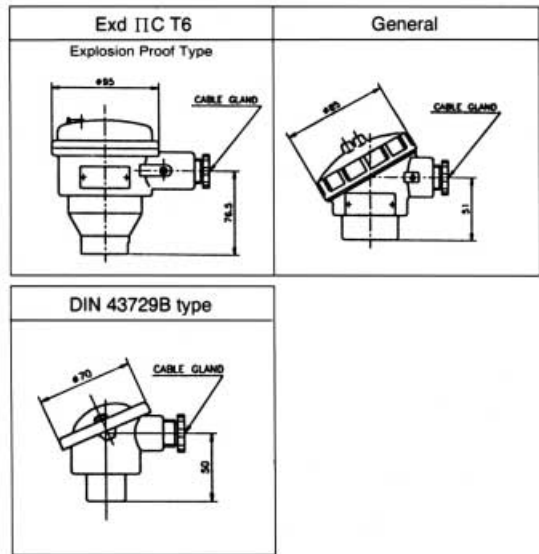

METALLIC PROTECTION TUBE THERMOCOUPLE
R111 : SINGLE ELEMENT
R112 : DOUBLE ELEMENT



ORDERING INFORMATION

BASE MODEL - 1st thru 4th characters

R111 : SINGLE ELEMENT

R112 : DOUBLE ELEMENT

5th Character

CODE	HEAD TYPE
A	General Explosion Proof
F	DIN(43729B)
L	

6th Character

CODE	ELEMENT TYPE
K	K
J	J
T	T
E	E
Z	Other

7th Character

CODE	PROTECTION TUBE MATERIAL
0	304SS
1	316SS
2	INCONEL 600
3	310SS
4	446SS
5	347SS
6	321SS
9	Other

8th and 9th Characters

CODE	PROTECTION TUBE & ELEMENT OUTDIA METER
F0	6.4 & 0.65mm
F1	6.4 & 1.0mm
G1	8.0 & 1.0mm
J1	10.0 & 1.0mm
J2	10.0 & 1.6mm
K1	12.0 & 1.0mm
K2	12.0 & 1.6mm
M1	15.0 & 1.0mm
M2	15.0 & 1.6mm
M3	15.0 & 2.3mm
P2	17.3 & 1.6mm
P3	17.3 & 2.3mm
P4	17.3 & 3.2mm
Q3	21.7 & 2.3mm
Q4	21.7 & 3.2mm

10th Character

CODE	CONDUIT CONNECTION
1	1/2"PF(Only available for single element)
2	1/2"PT(Only available for single element)
3	1/2"NPT(Only available for single element)
*4	3/4"PF(Only available for double element)
*5	3/4"PT(Only available for double element)
*6	3/4"NPT(Only available for double element)
	* DIN(43729B) Head Type is not available for 3/4"Connection

11th Character

CODE	MOUNTING TYPE
X	Refer to Mounting Type Table

12th Character

CODE	CONNECTION TYPE
XX	Refer to Connection Type Table

14th Character

CODE	INSERT LENGTH
X	Refer to Insert Length Table

15th Character

CODE	OPTIONS
0	None
1	Accessories

R111FK0G12REBEO
SAMPLE ORDERING NUMBER

RP01 - 01

SHEATHED THERMOCOUPLE
R121 : SINGLE ELEMENT
R122 : DOUBLE ELEMENT



ORDERING INFORMATION

BASE MODEL - 1st thru 4th characters

R121 : SINGLE ELEMENT

R122 : DOUBLE ELEMENT

5th Character

CODE	HEAD & TIP SHAPE TYPE
A	General & Ungrounded
B	General & Ungrounded & Spring-Loaded
C	General & Grounded
D	General & Grounded & Spring-Loaded
E	General & Exposed
F	Explosion Proof & Ungrounded
G	Explosion Proof & Ungrounded & Spring-Loaded
H	Explosion Proof & Grounded
J	Explosion Proof & Grounded & Spring-Loaded
K	Explosion Proof & Exposed
L	DIN(43729B) & Ungrounded
M	DIN(43729B) & Grounded
N	DIN(43729B) & Exposed

6th Character

CODE	ELEMENT TYPE
K	K
J	J
T	T
E	E
R	R
S	S
B	B
Z	Other

7th Character

CODE	SHEATH MATERIAL
1	316SS
2	INCONEL 600
3	310SS
4	446SS
5	347SS
6	321SS
9	Other

8th Character

CODE	SHEATH OUTDIA METER
*A9	1.0mm
*B9	1.6mm
C9	2.3mm
D9	3.2mm
E9	4.8mm
F9	6.4mm
G9	8.0mm
H9	9.5mm
L9	12.7mm

*Double Element is not available for 1.0 & 1.6mm sheath outdia.

10th Character

CODE	CONDUIT CONNECTION
1	1/2"PF(Only available for single element)
2	1/2"PT(Only available for single element)
3	1/2"NPT(Only available for single element)
*4	3/4"PF(Only available for double element)
*5	3/4"PT(Only available for double element)
*6	3/4"NPT(Only available for double element)

* DIN(43729B) Head Type is not available for 3/4" Conduit Connection

11th Character

CODE	MOUNTING TYPE
X	Refer to Mounting Type Table

12th and 13th Characters

CODE	CONNECTION TYPE
XX	Refer to Connection Type Table

14th Character

CODE	INSERT LENGTH
X	Refer to Insert Length Table

15th Character

CODE	OPTIONS
0	None
1	Accessories

R121FK1F92REBE0
SAMPLE ORDERING NUMBER

RP01 - 02

**METALLIC PROTECTION TUBE RESISTANCE
TEMPERATURE DETECTOR
R211 : SINGLE ELEMENT
R212 : DOUBLE ELEMENT**



ORDERING INFORMATION

BASE MODEL - 1st thru 4th characters

R211 : SINGLE ELEMENT

R212 : DOUBLE ELEMENT

5th Character

CODE	HEAD TYPE
A	General
F	Explosion Proof
L	DIN(43729B)

6th Character

CODE	ELEMENT TYPE
P	Pt 100 Ω

7th Character

CODE	PROTECTION TUBE
0	304SS
1	316SS
9	Other

8th and 9th Characters

CODE	PROTECTION TUBE OUTDIA METER
F9	6.4mm
G9	8.0mm
J9	10.0mm
K9	12.0mm

10th Character

CODE	CONDUIT CONNECTION
1	1/2"PF(Only available for Single Element)
2	1/2"PT(Only available for Single Element)
3	1/2"NPT(Only available for Single Element)
*4	3/4"PF(Only available for Double Element)
*5	3/4"PT(Only available for Double Element)
*6	3/4"NPT(Only available for Double Element)

* DIN(43729B) Head Type is not available for 3/4" Conduit Connection

11th Character

CODE	MOUNTING TYPE
X	Refer to Mounting Type Table

12th and 13th Characters

CODE	CONNECTION TYPE
XX	Refer to Connection Type Table

14th Character

CODE	INSERT LENGTH
X	Refer to Insert Length Table

15th Character

CODE	OPTIONS
0	None
1	Accessories

**R211FP1G92REBEO
SAMPLE ORDERING NUMBER**

SHEATHED RESISTANCE TEMPERATURE DETECTOR
R221 : SINGLE ELEMENT
R222 : DOUBLE ELEMENT



ORDERING INFORMATION

BASE MODEL - 1st thru 4th characters

R221 : SINGLE ELEMENT

R222 : DOUBLE ELEMENT

5th Character

CODE	HEAD TYPE
A	General
B	General & Spring-Loaded
F	Explosion Proof
G	Explosion Proof & Spring-Loaded
L	DIN(43729B)

6th Character

CODE	ELEMENT TYPE
Q	Pt 100 Ω

7th Character

CODE	SHEATH MATERIAL
1	316SS
2	INCONEL 600
3	310SS
4	446SS
5	347SS
6	321SS
9	Other

8th and 9th Characters

CODE	SHEATH OUTDIA METER
D9	3.2mm
E9	4.8mm
F9	6.4mm
G9	8.0mm

*Double Elements is not available for 3.2mm sheath outdia.

10th Character

CODE	CONDUIT CONNECTION
1	1/2"PF(Only available for Single Element)
2	1/2"PT(Only available for Single Element)
3	1/2"NPT(Only available for Single Element)
*4	3/4"PF(Only available for Double Element)
*5	3/4"PT(Only available for Double Element)
*6	3/4"NPT(Only available for Double Element)

* DIN(43729B) Head Type is not available for 3/4" Conduit Connection

11th Character

CODE	MOUNTING TYPE
X	Refer to Mounting Type Table

12th and 13th Characters

CODE	CONNECTION TYPE
XX	Refer to Connection Type Table

14th Character

CODE	INSERT LENGTH
X	Refer to Insert Length Table

15th Character

CODE	OPTIONS
0	None
1	Accessories

R221FQ1F92REBE0
 SAMPLE ORDERING NUMBER

RP02 - 02

EXTENSION LEAD WIRE THERMOCOUPLE &
RESISTANCE TEMPERATURE DETECTOR
R311 : SINGLE ELEMENT
R312 : DOUBLE ELEMENT
R321 : ARMORED LEAD TYPE SINGLE ELEMENT
R322 : ARMORED LEAD TYPE DOUBLE ELEMENT
R331 : BAYONET LOCKING TYPE SINGLE ELEMENT
R332 : BAYONET LOCKING TYPE DOUBLE ELEMENT



ORDERING INFORMATION

BASE MODEL - 1st thru 4th characters

R311 : SINGLE ELEMENT
R312 : DOUBLE ELEMENT
R321 : ARMORED LEAD TYPE SINGLE ELEMENT
R322 : ARMORED LEAD TYPE DOUBLE ELEMENT
R331 : BAYONET LOCKING TYPE SINGLE ELEMENT
R332 : BAYONET LOCKING TYPE DOUBLE ELEMENT

5th Character

CODE	HEAD TYPE
A	General
F	Explosion Proof
P	No Head

6th Character

CODE	ELEMENT TYPE
K	K
J	J
T	T
E	E
Q	Pt100Ω (Ceramic Type)
Z	Other

7th Character

CODE	SHEATH MATERIAL
1	316SS
2	INCONEL 600
3	310SS
4	446SS
5	347SS
6	321SS
9	Other

8th and 9th Characters

CODE	PROTECTION TUBE OUTDIA METER
D9	3.2mm
E9	4.8mm
F9	6.4mm
G9	8.0mm

10th Character

CODE	CONDUIT CONNECTION
1	1/2"PF(Only available for Single Element)
2	1/2"PT(Only available for Single Element)
3	1/2"NPT(Only available for Single Element)
*4	3/4"PF(Only available for Double Element)
*5	3/4"PT(Only available for Double Element)
*6	3/4"NPT(Only available for Double Element)
7	None

* DIN(43729B) Head Type is not available for 3/4" Conduit Connection

11th Character

CODE	MOUNTING TYPE
A	None
M	Movable Thread
N	Movable Flange
P	Compression Flange
X	Fixed Thread
Z	Other

12th and 13th Characters

CODE	CONNECTION TYPE
XX	Refer to Connection Type Table

14th Character

CODE	INSERT LENGTH
X	Refer to Insert Length Table

15th Character

CODE	OPTIONS
0	None
1	Accessories

R311PK1D91REB0
SAMPLE ORDERING NUMBER

MULTI THERMOCOUPLE & RESISTANCE TEMPERATURE DETECTOR

R511 : THERMOCOUPLE, SINGLE ELEMENT
 R512 : THERMOCOUPLE, DOUBLE ELEMENT
 R521 : RTD, SINGLE ELEMENT
 R522 : RTD, DOUBLE ELEMENT



ORDERING INFORMATION

BASE MODEL - 1st thru 4th characters

R511 : THERMOCOUPLE, SINGLE ELEMENT

R521 : RTD, SINGLE ELEMENT

R512 : THERMOCOUPLE, DOUBLE ELEMENT

R522 : RTD, DOUBLE ELEMENT

5th Character

CODE	HEAD TYPE
0	General & Protection Tube
1	General
2	Explosion Proof & Spring-Loaded
3	Explosion Proof
9	Other

6th Character

CODE	HEAD EXTENSION TYPE & SEALING LOCATION
0	Nipple & Head
1	Nipple & Flange
2	Union- Nipple & Head
3	Union- Nipple & Flange
9	Other

7th Character

CODE	ELEMENT TYPE
K	K
J	J
T	T
E	E
Q	Pt 100Ω (Ceramic Type)
Z	Other

8th Character

CODE	NUMBER OF MEASURING TEMPERATURE POINTS
A	2
B	3
C	4
D	5
E	6
F	7
G	8
H	9
J	10
K	11
L	12
M	13
N	14
P	15
Z	Other

9th Character

CODE	SHEATH OUTDIA METER
0	1.6mm
1	3.2mm
2	4.8mm
3	6.4mm
5	1.6mm/Weld Pad
6	3.2mm/Weld Pad
7	4.8mm/Weld Pad
8	6.4mm/Weld Pad

10th Character

CODE	SHEATH MATERIAL
1	316SS
2	INCONEL 600
3	310SS
4	446SS
5	347SS
6	321SS
9	Other

11th Character

CODE	PROTECTION TUBE MATERIAL
0	None
1	304SS
2	316SS
3	INCONEL 600
4	310SS
5	446SS
6	347SS
7	321SS
9	Other

12th Character

CODE	PROCESS CONNECTION
0	1"
1	1 1/4"
2	1 1/2"
3	2"
4	2 1/2"
5	3"
6	4"
7	6"
9	Other

13th Character

CODE	PROCESS CONNECTION TYPE
A	NPT
B	PT
C	ANSI 150# RF
D	ANSI 150# FF
E	ANSI 300# RF
F	ANSI 300# FF
G	ANSI 600# RF
H	ANSI 600# FF
J	ANSI 900# RF
K	ANSI 900# FF
L	ANSI 1500# RF
M	ANSI 1500# FF
N	ANSI 1500# RTJ
P	ANSI 2500# RF
Q	ANSI 2500# FF
R	ANSI 2500# RTJ
S	JIS 10K RF
T	JIS 10K FF
U	JIS 20K RF
V	JIS 20K FF
Z	Other

14th Character

CODE	INSERT LENGTH
A	2m
B	3m
C	4m
D	5m
E	6m
F	7m
G	8m
H	9m
J	10m
K	15m
L	20m
M	25m
N	30m
P	35m
Q	40m
R	45m
S	50m
Z	Other

NOTE Please choose the longest among measuring points.

15th Character

CODE	OPTIONS
0	None
1	Accessories

R51101KC1122DD0
SAMPLE ORDERING NUMBER

SKIN THERMOCOUPLE

- R601 : HEAD ASSEMBLY, SINGLE ELEMENT
- R602 : HEAD ASSEMBLY, DOUBLE ELEMENT
- R611 : EXTENSION LEAD WIRE, SINGLE ELEMENT
- R612 : EXTENSION LEAD WIRE, DOUBLE ELEMENT



ORDERING INFORMATION

BASE MODEL - 1st thru 4th characters

- R601 : HEAD ASSEMBLY, SINGLE ELEMENT
- R611 : EXTENSION LEAD WIRE, SINGLE ELEMENT

- R602 : HEAD ASSEMBLY, DOUBLE ELEMENT
- R612 : EXTENSION LEAD WIRE, DOUBLE ELEMENT

5th Character

CODE	HEAD TYPE
C	General
H	Explosion Proof
Q	None, Extension Lead Wire
Z	Other

6th Character

CODE	ELEMENT TYPE
K	K
J	J
T	T
E	E
Z	Other

7th Character

CODE	SHEATH MATERIAL
1	316SS
2	INCONEL 600
3	310SS
4	446SS
5	347SS
6	324SS
9	Other

8th Character

CODE	SHEATH OUTDIA METER
D	3.2mm
E	4.8mm
F	6.4mm
G	8.0mm
H	9.5mm
L	12.7mm

9th Character

CODE	WELD PAD TYPE
7	Plate (Round or Flat)
*8	Knife Edge
5	Other

* Knife Edge Weld Pad Type is available for 9.5 & 12.7mm sheath outdia meter

10th Character

CODE	CONDUIT CONNECTION
1	1/2"PF(Only available for Single Element)
2	1/2"PT(Only available for Single Element)
3	1/2"NPT(Only available for Single Element)
*4	3/4"PF(Only available for Double Element)
*5	3/4"PT(Only available for Double Element)
*6	3/4"NPT(Only available for Double Element)

* DIN (43729B) Head Type is not available for 3/4" Conduit Connection

11th Character

CODE	MOUNTING TYPE
A	None
M	Movable Thread
N	Movable Flange
P	Compression Fitting
S	Union & Nipple
W	Nipple
X	Fixed Thread
Z	Other

12th and 13th Characters

CODE	CONNECTION TYPE
XX	Refer to Connection Type Table

14th Character

CODE	INSERT LENGTH
X	Refer to Insert Length Table

15th Character

CODE	OPTIONS
0	None
1	Accessories

R601HK1G72PEBE0
SAMPLE ORDERING NUMBER

NON-METALLIC PROTECTION TUBE THERMOCOUPLE
R701 : RTD, SINGLE ELEMENT
R702 : RTD, DOUBLE ELEMENT



ORDERING INFORMATION
BASE MODEL - 1st thru 4th characters
R701 : RTD, SINGLE ELEMENT
R702 : RTD, DOUBLE ELEMENT

5th Character

CODE	HEAD TYPE
0	General
1	Explosion Proof

6th Character

CODE	ELEMENT TYPE
R	R
S	S
B	B
K	K
Z	Other

7th Character

CODE	MOUNTING TYPE
A	None
B	Support Tube 100mm Length
C	Support Tube 150mm Length
D	Support Tube required Length
E	Fixed Thread 100mm Length
F	Fixed Thread 150mm Length
G	Fixed Thread required Length
H	Fixed Flange 100mm Length
J	Fixed Flange 150mm Length
K	Fixed Flange required Length
L	Movable Thread 100mm Length
M	Movable Thread 150mm Length
N	Movable Thread required Length
P	Movable Flange 100mm Length
Q	Movable Flange 150mm Length
R	Movable Flange required Length
Z	Other

8th and 9th Characters

CODE	OUTER PROTECTION TUBE OUTDIA METER
00	8.0mm
10	10.0mm
20	13.0mm
30	17.0mm
40	21.0mm
50	26.0mm
60	30.0mm
70	40.0mm
45	21.0mm
55	26.0mm
65	30.0mm

***Element "K" Type is only available with CODE45,55 AND 65
10th Character**

CODE	OUTER PROTECTION TUBE MATERIAL
1	SSA-S
2	SSA-H
3	HB
4	GK-SiC
5	INCONEL 600
6	446SS
7	Other

11th Character

CODE	INNER PROTECTION TUBE MATERIAL
0	None
1	SSA-S
2	SSA-H
3	HB
4	GK-SiC
9	Other

12th Character

CODE	CONNECTION
A	None
E	1/2"
F	3/4"
G	1"
H	1 1/4"
J	1 1/2"
K	2"
L	2 1/2"
M	3"
Z	Other

13th Character

CODE	CONNECTION TYPE
A	None
B	PT
C	NPT
D	PF
K	ANSI 150# RF
L	ANSI 150# FF
M	ANSI 300# RF
N	ANSI 300# FF
P	ANSI 600# RF
Q	ANSI 600# FF
R	JIS 5K RF
S	JIS 5K FF
T	JIS 10K RF
U	JIS 10K FF
V	JIS 20K RF
W	JIS 20K FF
Z	Other

15th Character

CODE	OPTIONS
0	None
1	Accessories

R7010RB0011ECD0
SAMPLE ORDERING NUMBER

14th Character

CODE	INSERT LENGTH
A	100mm
B	200mm
C	300mm
D	400mm
E	500mm
F	600mm
G	700mm
H	800mm
J	900mm
K	1000mm
L	1500mm
M	2000mm
N	2500mm
P	3000mm
Q	3500mm
R	4000mm
S	4500mm
T	5000mm
U	6000mm
V	7000mm
W	8000mm
X	9000mm
Y	10000mm
Z	Other

Note : Please choose a code of next higher length if applicable length is not. Actual length shall be specified.

TEMPERATURE TRANSMITTER
R911: THERMOCOUPLE
R912: RESISTANCE TEMPERATURE DETECTOR



ORDERING INFORMATION
BASE MODEL - 1st thru 4th characters
R911: THERMOCOUPLE
R912: RESISTANCE TEMPERATURE DETECTOR

5th Character

CODE	HEAD & TIP SHAPE TYPE
F	Explosion Proof & Ungrounded
G	Explosion Proof, Ungrounded Spring-Loaded
H	Explosion Proof & Grounded
J	Explosion Proof Grounded Spring-Loaded

6th Character

CODE	ELEMENT TYPE
K	K
J	J
T	T
E	E
Q	Pt100 Ω (Ceramic Type)

7th Character

CODE	SHEATH MATERIAL
1	316SS
2	INCONEL 600
3	310SS
4	446SS
5	347SS
6	321SS
9	Other

8th and 9th Characters

CODE	SHEATH OUTDIA METER
D9	3.2mm
E9	4.8mm
F9	6.4mm
G9	8.0mm

10th Character

CODE	CONDUIT CONNECTION
1	1/2"PF
2	1/2"PT
3	1/2"NPT

11th Character

CODE	MOUNTING TYPE
x	Refer to Mounting Type Table

12th and 13th Characters

CODE	CONNECTION TYPE
XX	Refer to Connection Type Table

14th Character

CODE	INSERT LENGTH
X	Refer to Insert Length Table

15th Character

CODE	OPTIONS
0	None
1	Accessories

R911FK1F92REBEO
SAMPLE ORDERING NUMBER

Mounting, Connection Type and Insert Length Table
-11th thru 14th characters

11th Character		12th Character		13th Character		14th Character	
CODE	MOUNTING	CODE	Connection Size & Connector Material	CODE	CONNECTION TYPE	CODE	Insert Length(mm)
A	None	A	None	A	None	A	100mm
B	Fixed Thread Lag Length 80mm 100mm 150mm 200mm Other	B	1/8" & 304SS	B	PT	B	200mm
C		C	1/4" & 304SS	C	NPT	C	300mm
D		D	3/8" & 304SS	D	PF	D	400mm
E		E	1/2" & 304SS	E	NPS	E	500mm
F		F	3/4" & 304SS	F	UNF	F	600mm
G		Fixed Flange Lag Length 80mm 100mm 150mm	G	1" & 304SS	G	BSPT	G
H	H		1 1/4" & 304SS	H	BSPF	H	800mm
J	J		1 1/2" & 304SS	J	MM	J	900mm
K	Fixed Flange Lag Length 200mm Other	K	2" & 304SS	K	ANSI 150# RF	K	1000mm
L		L	3" & 304SS	L	ANSI 150# FF	L	1500mm
M	Movable Thread	M	7/16" & 304SS	M	ANSI 300# RF	M	2000mm
N	Movable Flange	N	1/8" & 316SS	N	ANSI 300# FF	N	2500mm
P	Compression Fitting	P	1/4" & 316SS	P	ANSI 600# RF	P	3000mm
Q	Union & Nipple Length 100mm Length 150mm Length Other	Q	3/8" & 316SS	Q	ANSI 600# FF	Q	3500mm
R		R	1/2" & 316SS	R	JIS 5K RF	R	4000mm
S		S	3/4" & 316SS	S	JIS 5K FF	S	4500mm
T	Nipple Length 50mm 100mm 150mm Other	T	1" & 316SS	T	JIS 10K RF	T	5000mm
U		U	1 1/4" & 316SS	U	JIS 10K FF	U	6000mm
V		V	1 1/2" & 316SS	V	JIS 20K RF	V	7000mm
W		W	2" & 316SS	W	JIS 20K FF	W	8000mm
X	Fixed Thread	X	3" & 316SS	X	ANSI 1500# RTJ	X	9000mm
Y		Y	7/16" & 316SS	Y	ANSI 2500# RTJ	Y	10000mm
Z	Other	Z	Other	Z	Other	Z	Other

Note For 14th Character, please choose a code of next higher length if applicable length is not. Actual length shall be specified.

TEMPERATURE TRANSMITTER
MODEL : MTM

WISE[®]

- High reliability and accuracy
- Head mounting type
- DC 4~20mA, 2-wire design



Standard Features

ACCURACY : $\pm 0.3\%$ of Full Scale
MEASURING : Pt 100ohm 0~500°C
 'K' Type T/C : 0~800°C
 'J' Type T/C : 0~500°C
 'E' Type T/C : 0~250°C
 'T' Type T/C : 0~250°C
CURRENT OUTPUT : 4~20mA, DC
POWER : 12~30V, DC
BURN-OUT : Up-Scale or Down-Scale
MOUNTING : Head Mounting
HOUSING : Plastic
SIZE : 50 \varnothing X 35mm
WEIGHT : 62g

ORDERING INFORMATION

BASE MODEL

MTM : TEMPERATURE TRANSMITTER

SENSOR TYPE

RJ : Pt 100 ohm, JIS-C-1604-1981
 RD : Pt 100 ohm, IEC, DIN, JIS-C-1604-1981
 TK : 'K' Type Thermocouple
 TJ : 'J' Type Thermocouple
 TE : 'E' Type Thermocouple
 TT : 'T' Type Thermocouple

MEASURING RANGE (Refer to Measuring Range Table)

XX

BURN-OUT

U : Up Scale
 D : Down Scale, Pt 100 ohm Only

MTM RJ 05 U MTMRJ05U SAMPLE ORDERING NUMBER

PRESSURE RANGE TABLE

CODE	RANGE(°C)	CODE	RANGE(°C)	CODE	RANGE
05	0~50°C	50	0~500°C	13	100~300
10	0~100°C	60	0~600°C	N0	-50~50
15	0~150°C	70	0~700°C	N1	-50~100
20	0~200°C	80	0~800°C	N5	-50~150
25	0~250°C	51	50~100°C	N2	-50~200
30	0~300°C	55	50~150°C	ZZ	SPECIAL
40	0~400°C	12	100~200°C		

THERMOCOUPLES & ASSEMBLIES

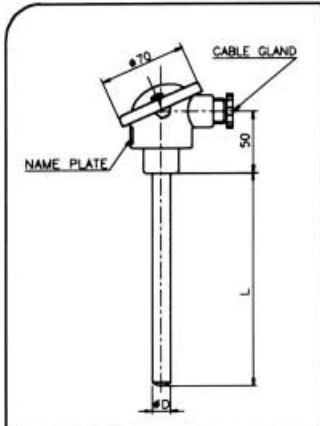

FIG. NO. 1

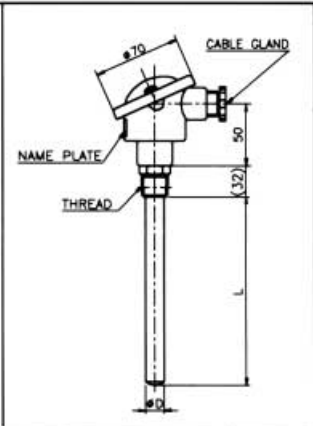

FIG. NO. 2

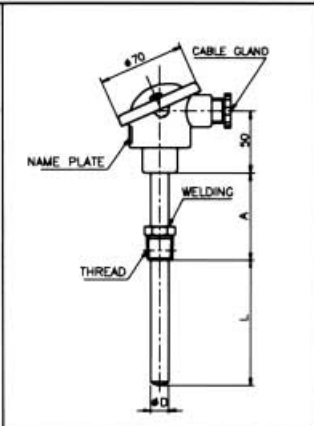

FIG. NO. 3

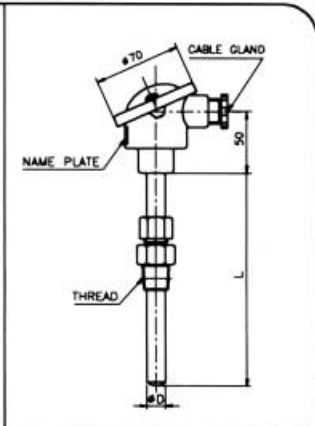

FIG. NO. 4

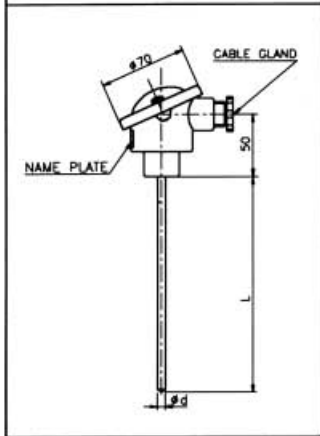

FIG. NO. 5

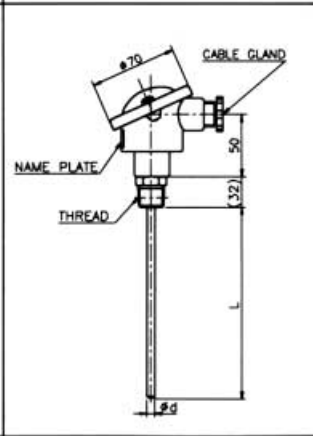

FIG. NO. 6

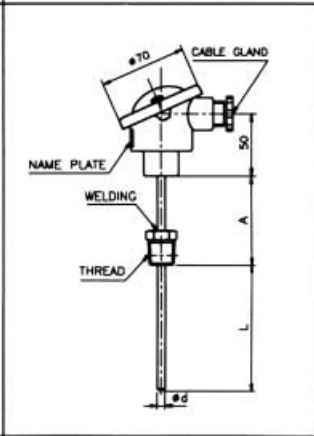

FIG. NO. 7

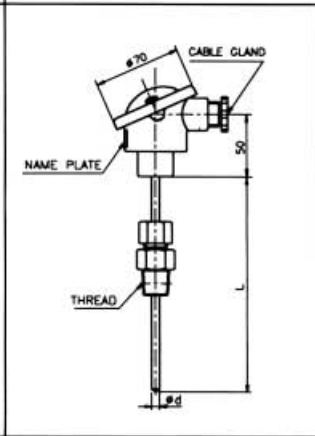
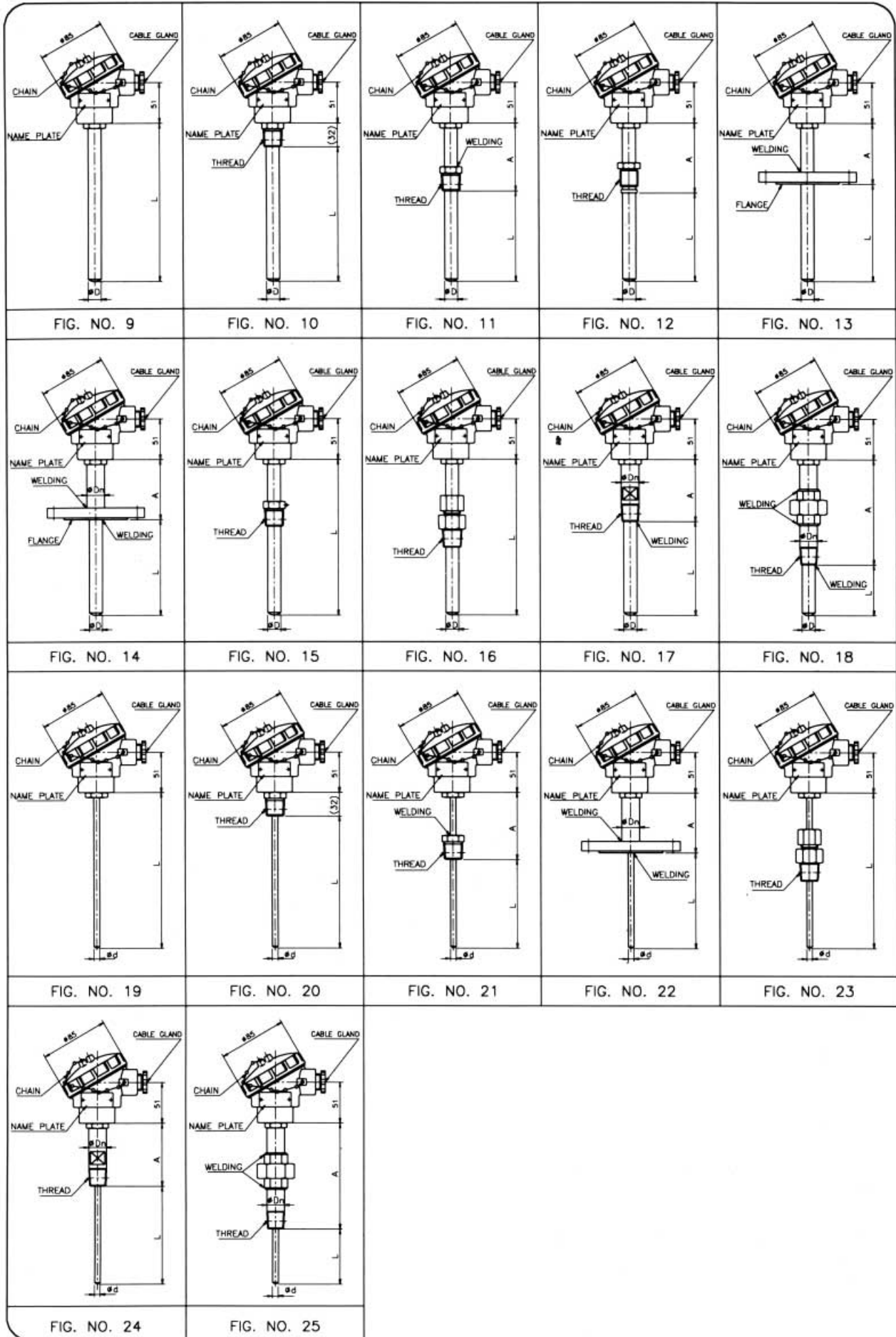
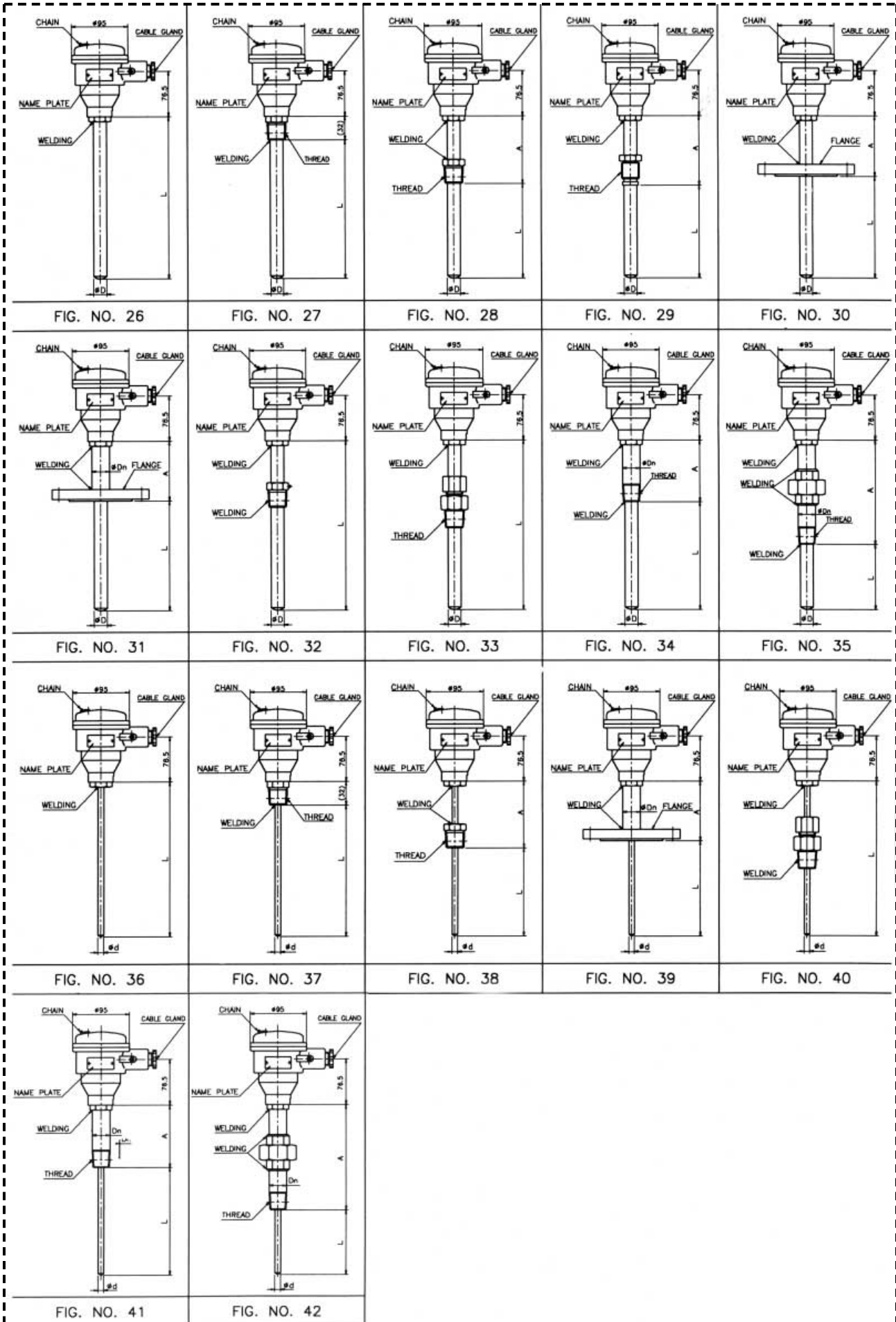
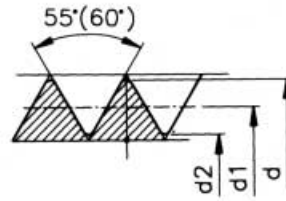
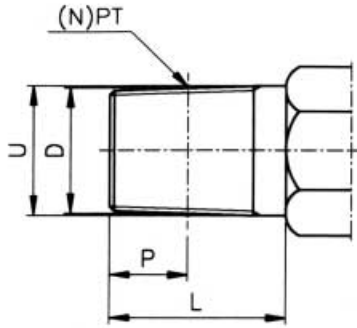

FIG. NO. 8







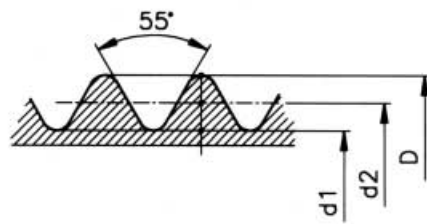
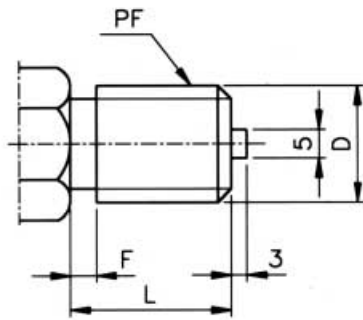

UNIT:mm

		D	D1	P	L	n	d	d1	d2
N P T	1/16	7.938	7.142	4.064	12	27	7.938	7.142	8.566
	1/8	10.238	9.489	4.102	12	27	10.238	9.489	8.766
	1/4	13.716	12.487	5.786	14	18	13.716	12.487	11.314
	3/8	17.145	15.926	6.096	16	18	17.145	15.926	14.797
	1/2	21.336	19.772	8.128	18	14	21.336	19.772	18.321
	3/4	26.670	25.117	8.611	20	14	26.670	25.117	23.666
	1	33.401	31.461	10.160	22	11.5	33.401	31.461	29.694
	1 1/4	42.164	40.218	10.668		11.5	42.164	40.218	38.451
	1 1/2	48.260	46.287	10.668		11.5	48.260	46.287	44.520
	2	60.325	58.325	11.074		11.5	60.325	58.325	56.558
	2 1/2	73.025	70.159	17.323		8	73.025	70.159	67.619
	3	88.900	86.068	19.456		8	88.900	86.068	83.528
P T	1/8	9.728	9.147	3.97	12	28	9.728	9.147	8.566
	1/4	13.157	12.301	6.01	14	19	13.157	12.301	11.445
	3/8	16.662	15.806	6.35	16	19	16.662	15.806	14.950
	1/2	20.955	19.793	8.16	18	14	20.955	19.793	18.631
	3/4	26.441	25.279	9.53	20	14	26.441	25.279	24.117
	1	33.249	31.770	10.39	22	11	33.249	31.770	30.291
	1 1/4	41.920	40.431	12.70		11	41.920	40.431	38.952
	1 1/2	47.803	46.324	12.70		11	47.803	46.324	44.845
2	59.610	58.135	15.8		11	59.610	58.135	56.656	



		D	L	F	n	d1	d2
P F	1/8	9.728	14	2	28	8.566	9.147
	1/4	13.157	16	2	19	11.445	12.301
	3/8	16.662	18	2	19	14.950	15.806
	1/2	20.955	20	2.5	14	18.631	19.793
	5/8	22.911		3	14	20.587	21.749
	3/4	26.441	22	3	14	24.877	25.279
	7/8	30.201			14	27.877	29.039
	1	33.249	24		11	30.291	31.770
	1 1/8	37.897			11	34.939	36.418
	1 1/4	41.910			11	38.952	40.431
	1 1/2	47.803			11	44.845	46.324

()

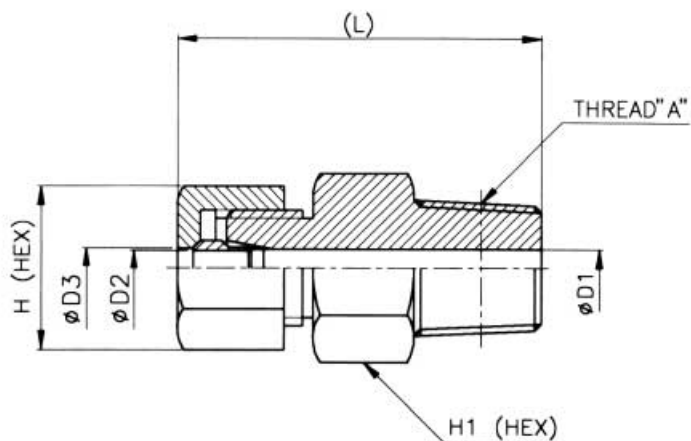

CODE	PIPE DIA	THREAD "A"	φ D1	φ D2	φ D3	H1 (HEX)	H (HEX)	(L)
4018100001	φ 3.2	PT1/4	3.4	3.2	3.6	17×19.6	14×16.2	
4018100002		PT3/8				19×21.7		
4018100003		PT1/2				22×25.4		
4018100004	φ 4.8	PT1/4	5	4.8	5.2	17×19.6	14×16.2	
4018100005		PT3/8				19×21.7		
4018100006		PT1/2				22×25.4		
4018100007	φ 6.4	PT1/4	6.6	6.4	6.8	17×19.6	14×16.2	
4018100008		PT3/8				19×21.7		
4018100009		PT1/2				22×25.4		
4018100010	φ 8.0	PT1/4	8.2	8.0	8.4	17×19.6	17×19.6	
4018100011		PT3/8				19×21.7		
4018100012		PT1/2				22×25.4		
4018100013	φ 10	PT3/8	10.2	10	10.4	19×21.7	19×21.7	
4018100014		PT1/2				22×25.4		
4018100015	φ 12	PT1/2	10.2	10	12.4	22×25.4	22×25.4	

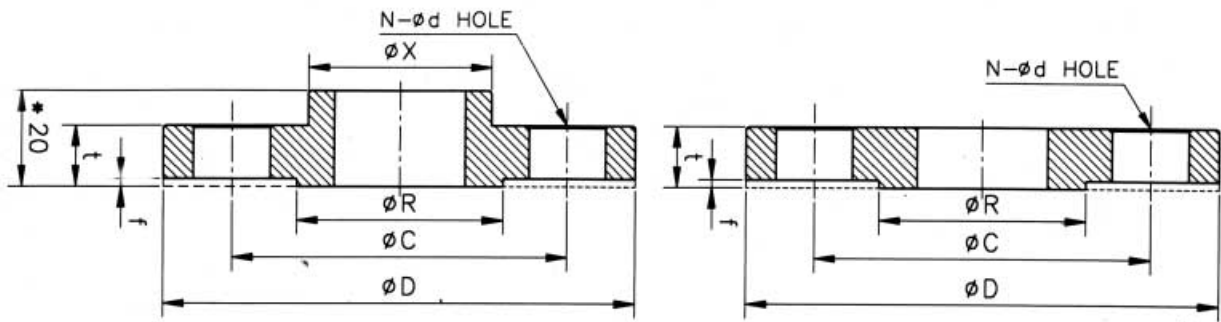

* In case that thickness(t) is less than 20mm.

"RF,FF" TYPE

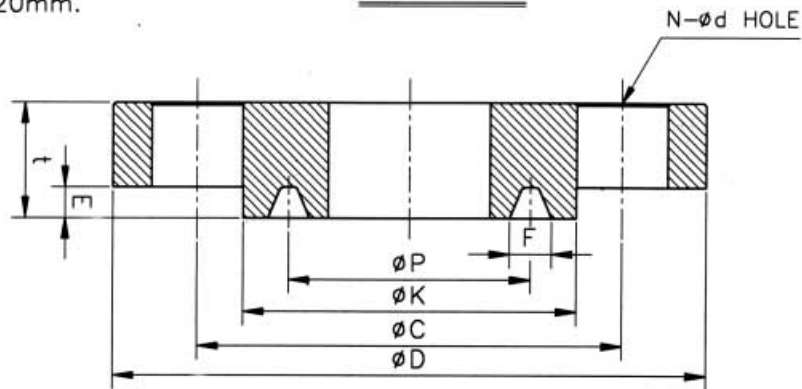

"RTJ" TYPE

STD.	NPS	CLASS	D	C	R	K	P	E	F	X	t	f	N	d	
ANSI (RF, FF)	3/4"	150	98.5	69.9	42.9					38.1	12.7	1.6	4	16	
	1"		108	79.4	50.8					49.2	14.3			16	
	1 1/2"		127	98.4	73.1					65.1	17.5			16	
	2"		152.4	120.6	92.1					65.1	19.1			19	
	3/4"	300	117.5	82.6	42.9					47.6	15.9	1.6	4	19	
	1"		123.9	88.9	50.8					54	17.5			19	
	1 1/2"		155.6	114.3	73.1						20.7			22	
	2"		165.1	127	92.1						22.3			8	19
	1"	600	123.9	88.9	50.8						23.9	6.35	4	19	
	1 1/2"		155.6	114.3	73.1						28.6			22	
	2"		165.1	127	92.1						31.8			8	19
	1"		149.3	101.6	50.8						35			4	25
1 1/2"	1500	177.8	123.8	73.1						38.1	6.35	4	28		
2"		215.9	165.1	92.1						44.5			8	25	
ANSI (RTJ)	1"	1500	149.3	101.6		71.43	50.8	6.35	8.73		35	1	4	25	
	1 1/2"		177.8	123.8		92.07	68.26	6.35	8.73		38.1			28	
	2"		215.9	165.1		123.82	95.25	7.93	11.9		44.5			8	25
	1"	2500	158.8	107.95		82.55	60.32	6.35	8.73		41.3	1	4	25	
	1 1/2"		203.2	146.05		114.3	82.55	7.93	11.9		50.8			32	
	2"		235	171.45		133.35	101.6	7.93	11.9		57.2			8	28
JIS (RF, FF)	15A	10K	95	70	52					45	12	1	4	15	
	20A		100	75	58					50	14			15	
	25A		125	90	70					50	14			19	
	15A	20K	95	70	52					45	14	1	4	15	
	20A		100	75	58					50	16			15	
	25A		125	90	70					50	16			19	