



RCR
Pneumatic Actuator
for
180 Deg.





Pneumatic Actuators for 180°



For application on valves with rotary motion between 0° - 180°

CONSTRUCTION

RCR pneumatic actuators consist of a housing in anodized aluminium (1) and two pistons (2), both with one rack. These racks are engaged in the gear which is formed by the middle part of the shaft (3).

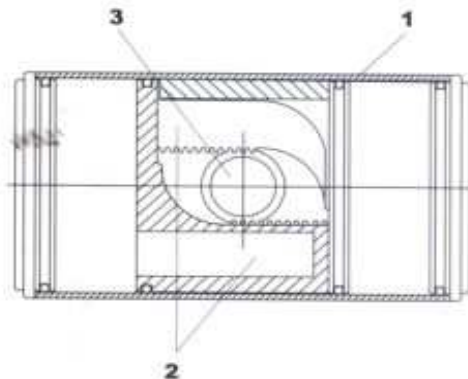

When compressed air through bored canals is led to the space between the pistons and each end plate, the air presses the pistons towards the centre whereby the shaft is turned 180°.

If the compressed air is led between the two pistons and vents the outer chambers, the shaft will revert 180°.

RCR 180° Actuators

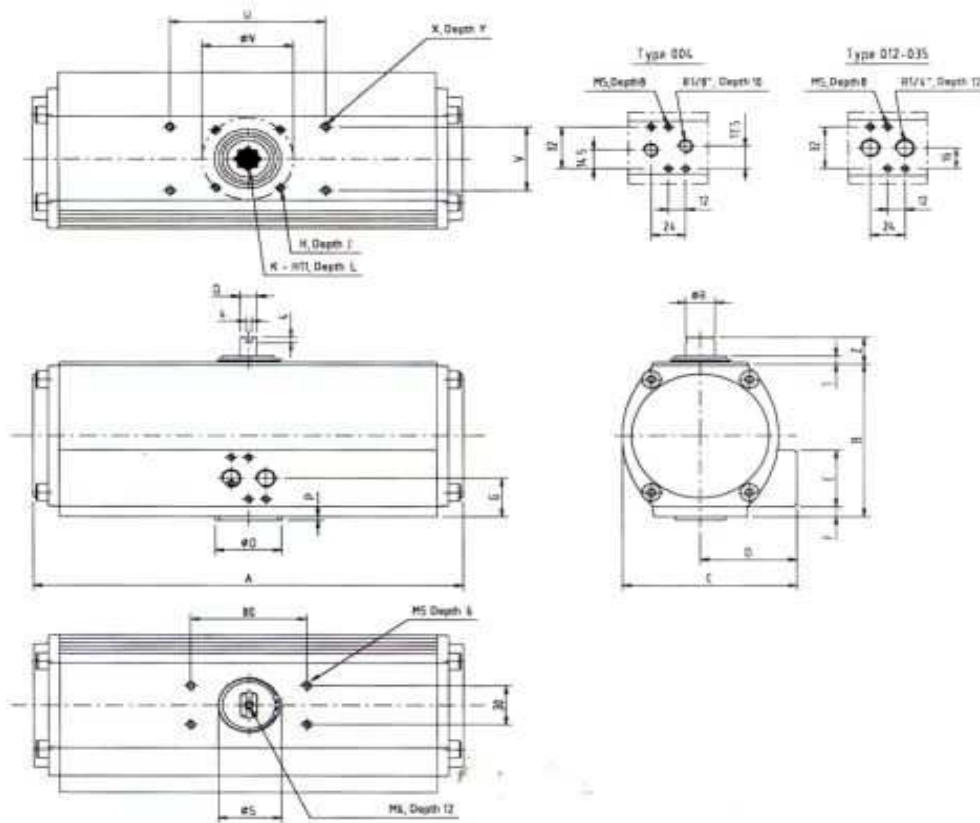

| Type | Article No. | A | B | C | D | E | F | G | H | J | K H11 | L min |
|--------|-------------|-----|-------|-------|------|----|-----|------|-----|----|-------|-------|
| RCR004 | 210001 | 215 | 90.5 | 87.5 | 47.5 | 41 | - | 20.5 | M5 | 10 | 11 | 12 |
| RCR012 | 210003 | 295 | 118.5 | 121.0 | 67.0 | 43 | 8.0 | 29.5 | M8 | 13 | 17 | 16 |
| RCR020 | 210004 | 337 | 140.5 | 136.5 | 72.0 | 43 | 8.0 | 29.5 | M8 | 13 | 17 | 19 |
| RCR035 | 210005 | 402 | 166.5 | 165.0 | 78.0 | 43 | 8.5 | 30.0 | M10 | 16 | 22 | 24 |

| Type | Article No. | Ø N | Ø O | P | Q | Ø R | Ø S | T | U | V | X | Y min | Z |
|--------|-------------|-----|-----|---|------|-----|-----|-----|-----|----|----|-------|----|
| RCR004 | 210001 | 42 | 30 | 2 | 11.5 | 20 | Ø1 | 4.5 | 73 | 32 | M5 | 8 | 20 |
| RCR012 | 210003 | 70 | 55 | 3 | 11.5 | 20 | 46 | 5.5 | 107 | 49 | M6 | 10 | 20 |
| RCR020 | 210004 | 70 | 55 | 3 | 19.0 | 32 | 50 | 6.5 | 120 | 60 | M6 | 10 | 20 |
| RCR035 | 210005 | 102 | 70 | 3 | 19.0 | 32 | 61 | 7.0 | 161 | 73 | M8 | 12 | 20 |

Torque in Nm, air pressure in bar.

| Type | Article No. | 2 bar | 3 bar | 4 bar | 5 bar | 5.5 bar | 6 bar | 7 bar | 8 bar | 9 bar | 10 bar |
|--------|-------------|-------|-------|-------|-------|---------|-------|-------|-------|-------|--------|
| RCR004 | 210001 | 15 | 22 | 30 | 37 | 41 | 45 | 52 | 60 | 67 | 76 |
| RCR012 | 210003 | 43 | 66 | 89 | 111 | 122 | 134 | 157 | 180 | 202 | 225 |
| RCR020 | 210004 | 75 | 112 | 150 | 187 | 206 | 224 | 262 | 299 | 337 | 374 |
| RCR035 | 210005 | 135 | 203 | 271 | 339 | 373 | 408 | 476 | 544 | 612 | 680 |



Remote Control Sweden AB - Kontrollvägen 15 - SE-791 45 Fokun - Sweden - Tel. +46(0)23 58700 - Fax +46(0)23 58745
 r.fokun@remotecontrol.se - www.remotecontrol.se

Ref No 5218 / Art No 180021